

Beauty and the Beast

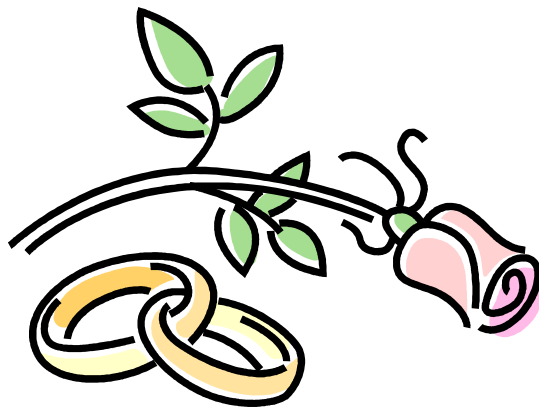

A Pantomime
by
Toby Bradford & Tina Webster

This script is published by

NODA LTD
 15 The Metro Centre
 Peterborough PE2 7UH
 Telephone: 01733 374790
 Fax: 01733 237286
 Email: info@noda.org.uk
www.noda.org.uk

To whom all enquiries regarding purchase of further scripts and current royalty rates should be addressed.

CONDITIONS

1. A Licence, obtainable only from NODA Ltd, must be acquired for every public or private performance of a NODA script and the appropriate royalty paid : if extra performances are arranged after a Licence has already been issued, it is essential that NODA Ltd be informed immediately and the appropriate royalty paid, whereupon an amended Licence will be issued.
2. The availability of this script does not imply that it is automatically available for private or public performance, and NODA Ltd reserve the right to refuse to issue a Licence to Perform, for whatever reason. Therefore a Licence should always be obtained before any rehearsals start.
3. All NODA scripts are fully protected by copyright acts. Under no circumstances may they be reproduced by photocopying or any other means, either in whole or in part, without the written permission of the publishers
4. The Licence referred to above only relates to live performances of this script. A separate Licence is required for videotaping or sound recording of a NODA script, which will be issued on receipt of the appropriate fee.
5. NODA works must be played in accordance with the script and no alterations, additions or cuts should be made without the prior consent from NODA Ltd. This restriction does not apply to minor changes in dialogue, strictly local or topical gags and, where permitted in the script, musical and dancing numbers.
6. The name of the author shall be stated on all publicity, programmes etc. The programme credits shall state "Script provided by NODA Ltd, Peterborough PE1 2RZ"

NODA LIMITED is the trading arm of the NATIONAL OPERATIC & DRAMATIC ASSOCIATION, a registered charity devoted to the encouragement of amateur theatre.

Beauty and the Beast

A traditional style, family pantomime, set in the village of Petit Pois, in France.

Cast List

BELLE	The principal girl. Spirited and strong-charactered.
PRINCE LOUIS	The Principal Boy. Slightly spoiled, but good natured.
THE BEAST	Wears make-up/mask, a strong performance required.
MADAME DOLORES LILLY CHANTILLY TRES JOLIE (DAME DOLLY)	Traditional pantomime Dame. Flirty and fun.
CHARDONNAY	Belle's older sister. Comedy role.
LAMBRINI	Belle's older sister. Comedy role.
JEAN-CLAUDE	Handsome, but vain, self-obsessed & egotistical.
JACQUES	Prince Louis's valet and best friend. Can be played as a second Principal Boy.
THE ROSE FAIRY	Traditional Panto Fairy. Good and kind – .. a French accent, if possible!
COUNTESS CRUELLA	Traditional Panto Baddie. She wants to marry Prince Louis, and will stop at nothing.
PAPA	Belle's Father, Dame Dolly's Husband. Hard-working, down-trodden and kind.
GIGI	The pantomime horse (two people).
MADAME BOTOX	The manager of Le Salon Beauty Parlour (one scene only)
CHELSEA / TIFFANY / SVEN / TARQUIN	Beauty Parlour employees (one scene only)
MADAME TRICOT	Old lady. A bit of a busy-body. Sits at the café, knitting.
PORTRAIT CHARACTER	Speaks from behind a gauze portrait (one scene only)
SUIT OF ARMOUR	Small role, two short lines (two scenes)
JEAN-CLAUDE'S P.A.	Non-speaking role (one scene only)

ROLES FOR CHORUS AND DANCERS:-

Villagers / Courtiers / Beauty Parlour Employees / Snowflakes

A number of Villagers have speaking lines.

Scenes and Staging

Don't be daunted by the large number of scene changes! The staging can, in fact, be fairly simple. The only full-stage scenes are **The Village** and **The Castle**, and possibly **The Beauty Parlour**. **The Castle** scene is used five times, and many of the shorter scenes can be played simply **front of tabs**, if required. Additional Notes appear at the end of the script.

ACT I

Scene 1	The Village of Petit Pois, France	Full stage scene. Village backcloth. Various market stalls set out, selling fruit and vegetables, bread, cheeses etc.
Scene 2	A Woodland Clearing	Front of tabs or front cloth scene. Add a couple of artificial trees and a tree stump or log
Scene 3	The Beauty Parlour	A half-stage (possibly full-stage?) scene (see Additional Notes for more details)
Scene 4	A Lane in the Village	A front cloth or tabs scene
Scene 5	The Castle of Prince Louis	A full stage scene. This scene is used five times, so it needs to look interesting for the audience! A plinth or pedestal is set up at one of the downstage corners, on which is placed the rose

ACT II

Prologue

		Front of tabs
Scene 6	In the Mountains	Cloth or tabs scene. A snowy mountain cloth would set the scene, but falling snow against a simple background can be very effective, too. (see Additional Notes for more staging details)
Scene 7	The Village of Petit Pois	As for Scene 1. However, if scene changes are difficult, this scene could easily become a front cloth or tabs scene & re-named A Lane in the Village
Scene 8	In the Mountains	As for Scene 6
Scene 9	The Castle of Prince Louis	As for scene 5, but there is now a table and two chairs set centre stage. (see Additional Notes for details of UV piece)
Scene 10	A Lane in the Village	A front cloth or tabs scene
Scene 11	The Castle of Prince Louis	As for scene 5, strike table & chairs, add a chaise longue upstage left
Scene 12	A Corridor in the Castle	A front cloth or tabs scene
Scene 13	The Castle of Prince Louis	As for Scene 11
Scene 14	A Corridor in the Castle	As for Scene 12 (front cloth or tabs)
Scene 15	The Castle of Prince Louis	As for Scene 11
Song Sheet		Front of tabs

Wedding Walk-Down and Bows

Full stage. As lavish a finale as desired

ACT I**Scene 1 The Village of Petits Pois, France**

Opening musical number . French-style music (or the theme tune to *Allo Allo*)
A short mime ballet

Then, dialogue begins in French

VILLAGER 1

Bonjour, Madame

VILLAGER 2

Bonjour Monsieur, comment allez-vous?

VILLAGER 1

Ca va bien, merci.

VILLAGER 3

Fleurs! Fleurs frais!

VILLAGER 4

Oignons! Oignons!

VILLAGER 5

Poissons! Poissons frais! Prix special aujourd'hui!

The scene continues in French, as the Rose Fairy enters – percussion bells as she casts a spell to silence the villagers

FAIRY

Hello my friends, and here we are
 In France, the Village Petits Pois
 You don't know me, I don't suppose
 Pleased to meet you! - Fairy Rose
 I have a special job to do
 To try and make some dreams come true
 A wonderful tale as old as time
 Will unfold in our pantomime
 A tale where true love finds a way
 - but it's all in French . is that OK?
 Oh dear . a problem now, I fear
 English there . and French up here
 You may not understand this now
 No matter . I will teach you how
 Repeat this after me . *Bonjour*

AUDIENCE

Bonjour

FAIRY

Comment vous appelez-vous, si vous plait?

AUDIENCE

(silent?)

FAIRY

Oh no . this isn't going too well
 I know! I'd cast a magic spell
 Then every word, you'd understand
 But you must help . I'd need a hand
 Close your eyes, just like me!
 Now concentrate . one, two, three!

Fairy waves wand to cast spell

(The following section may need to be altered, depending upon where your home town is situated!)

VILLAGER

(Brummy accent) Me Mam never used to let me mend me bike in the kitchen . so I had to mend it in the garden

FAIRY

What sort of language is this here?
 I think that **French** would be more clear!
 A little further north, we need
 Now concentrate! We will succeed!
 Now close your eyes again, like me
 I'd weave some magic . one, two, three

Fairy waves wand to cast spell, then opens eyes tentatively

VILLAGER

(Scottish accent) It's a brau brigd moonlit nigd the nigd

VILLAGER

Och aye, Mrs McTavish, it is yqken

FAIRY

We're too far north . we must move down
 You need to think about **your** town
That is where we need to be
 Third time lucky . one, two, three!

Fairy waves wand to cast spell ... opens eyes listens hopefully.

(This next section should be tailored to describe your own town)

VILLAGER

It was mayhem at the Cockpit Island again today!

FAIRY

Sounds hopeful!

VILLAGER

Have you seen that ugly concrete block they're building in the market place?

FAIRY

It's certainly ugly . no other town would allow it!

VILLAGER

I took my grandfather to the New City Hospital today . it's huge! By the time we'd reached Ward six thousand, four hundred and thirty eight, he'd died of old age!

This script is licensed for amateur theatre by NODA Ltd to whom all enquiries should be made.

www.noda.org.uk E-mail: info@noda.org.uk

FAIRY

We've done it! Now it will be clear
 You'll understand each word you hear
 Now quick! before we lose this spell
 We have a pantomime tale to tell

Fairy waves wand to cast spell, then exits

Villagers continue with their daily tasks

There is a bang and a flash from inside the café. The window opens, and smoke pours out - a hand wafts the smoke out with a tea-towel

VILLAGERS

What's that?! / What's happening?! / Oh no! (etc)

Dame Dolly runs out of the café, wailing

DAME

Ooooooh! õ õ õ That Jamie Oliver's got a lot to answer for . him and his %Bombe Surprise!
 I spent the very last money I had on the ingredients õ õ õ . but I think it got a little over-
 cooked õ . I'm usually a very good cook . but I can't even seem to manage that lately .
 everything I do seems to go wrong . (*sniffs into a hankie*) - just one disaster after anotherõ

VILLAGER

Don't worry õ õ . it'll be alright

VILLAGER

Of course it will!

SONG

%The Roses of Success+

DAME

Ooh, I feel better now! (*spots audience & moves forward*) Ooh hello! (*aside to wings*) The
 signposts worked then . we managed to redirect some of the regulars from %The Rose and
 Crown! (*replace with local pub*) Well, hello everybody! . (*peers out at the audience*) . oh
 there **is** someone out there! I thought you'd all gone home! I said hello everybody!

AUDIENCE

Hello!

DAME

How very nice to see you all! Let me introduce myself õ my name is Madame Dolores Lilly
 Chantilly Tres Jolie, so whenever I come on stage, I'll shout %Hello everyone!+and you can
 shout %Hello Madame Dolores Lilly Chantilly Tres Jolie+õ let's have a go! õ Hello everyone!

AUDIENCE

Hello õ õ õ õ

DAME

Hmmmm õ I don't think this is going to work, is it? Although I don't really agree with getting
 over-familiar too soon, I usually allow my friends to call me Dolly õ . Dolly Jollyõ õ and
 actually, you all look quite friendly (*peers out at audience*) ...well most of you! So **you** can
 call me Dolly. So now, when I say hello to you all, you can shout %Hello Dolly!qback to me õ
 shall we have a try? õ .. Hello everyone!

AUDIENCE

Hello Dolly!

This script is licensed for amateur theatre by NODA Ltd to whom all enquiries should be made.

www.noda.org.uk E-mail: info@noda.org.uk

DAME

Better than before . but I'm sure you could shout louder than that ò .. Hello everyone!

AUDIENCE

Hello Dolly!

DAME

Ooh, much better . I feel as though I'm amongst friends now. Here, have some sweeties!

They're **Dolly** Mixtures! *(throws sweets to audience)*

Now perhaps you can help me? I'm looking for my daughters . I don't suppose you've seen them have you?

Chardonnay & Lambrini are heard, off stage, squabbling.

DAME

Oh, sounds like them now ò .

Chardonnay & Lambrini enter, they are arguing

CHARDONNAY

I am the prettiest

LAMBRINI

No, I am the prettiest by far . haven't you looked in a mirror lately?

CHARDONNAY

At least I can look into a mirror **without** it cracking!

CHARDONNAY & LAMBRINI

Oh, hello Mama! *(both suddenly " nice")*

DAME

Don't you hello Mama! I've been looking everywhere for you . and where's your sister? *(to audience)* Oh I'm sorry, where are my manners? Let me introduce you to two of my three lovely daughters ò .. this is Chardonnay ò and this is Lambrini

Chardonnay & Lambrini sing a few lines of "We are the Cheeky Girls"

CHARDONNAY

Well hello boys and ò .

Lambrini pushes through to front

LAMBRINI

BOYS! *(scans audience)* He's nice!

CHARD

No, I fancy that one over there. He's gorgeous ò and he looks rich ò . look, he's wearing a brand new cardy

LAMB

Oooh yes! He's mine, I saw him first!

CHARD

Did not!

LAMB
Did too!

DAME
Now, now girls! *(to audience)* They're really very sweet and innocent you know

CHARD
Yes, I'm sweet ò .

LAMB
ò and I'm ò ò .. sweet as well!!

CHARD
You're not sweet . you're ugly!

LAMB
Ugly?! You're the one with a face like a gargoyle

CHARD
Ooooooh! Well you're got a face like a mushroom

LAMB
A mushroom??

CHARD
Yeah . best kept in the dark!

They are just about to hit each other, when Dame steps in to hold them apart

LAMB
Mama, Mama . I'm the pretty one, I'm the pretty one . tell Chard that I'm the pretty one!

CHARD
No Mama! I'm the pretty one . it's plainly obvious

LAMB
That you're obviously **plain**

The girls go for each other again

DAME
Oh you two! I'm going to settle this argument once and for all *(she looks at Chard then at Lamb, then at the audience)* Yes ò .. I'm the pretty one!

Chard & Lamb fall about laughing ending on the floor, legs in the air, showing some colourful large underwear

DAME
Charming!! Children these days have no respect. Personally, I blame the parents. Come on you two, stop making an exhibition of yourselves. How are you ever going to attract a wealthy husband lying on your back with your legs in the air?

Girls sit up

CHARD
It worked for Camill -

DAME

Chard'nay!! We canq afford to be sued!

You see boys and girls, Iqñ trying to marry my daughters off to rich husbands, so that they can keep me in the manner to which Iqñ like to become accustomed. Weqñ very poor you know ò .

AUDIENCE

Aaaah!

DAME

No, weqñ much poorer than that!

AUDIENCE

Aaaah!

DAME

I run this small café . xcompact and bijouqñs an understatement! . do you know, our kitchen is so small . I have to use **condensed** milk! The caféqñ not doing very well these days ò . no one seems to want afternoon tea on my best china . theyqñ rather eat a McDonaldqñ out of a cardboard box ò ò . I donq know what the worldqñ coming to. At one time, **this** was the place to be ò . my buns were the best in the business ò the best tart in Petits Pois ò . and if you wanted a nice bit of crumpet ò .

SONG %When Youqñ Good to Mamma+(from %Chicago+) . Dame Dolly

Anyway, where was I? ò oh, yes . we need more customers ò ò I think we need to brighten up the café .ò come along, girls . you can help me. And where IS your sister?

(Chard & Lamb shrug – they're not really bothered about Belle)

(to audience) Have you seen my other daughter, Belle? Sheqñ about this tall, and probably got her head in a book as usual . always reading, that girl. Will you let me know if you see her?

AUDIENCE

Yes!

DAME

Come on you two, help me look for Belle

They go to front of stage & peer forward.

Belle walks across the back of the stage, reading a book

Audience shouts (hopefully!)

DAME

Sorry? What did you say? Behind us? *(or react to what is shouted)*

Dame & sisters turn around just as Belle has exited the stage

DAME

Belleqñ not there!

AUDIENCE

Oh yes she is!

D, C & L

Oh no she isnq

AUD
Oh yes she is!

D,C & L
Oh no she isn't!

*Belle walks across in the opposite direction – audience shout – three turn around too late again. Three go to search at back of stage.
Belle walks across front of stage, stops in centre, continuing to read book. Three turn & are surprised to see Belle. They go over to Belle*

DAME
Oh, there you are, Belle. Your sisters and I have been worried about you, haven't we?

C & L
No!!

BELLE
Oh hello Mama. I was lost in this story . the girl has just met the most handsome prince ..

C & L
(mocking) The girl has just met the most handsome prince

CHARD
Come back to the **real** world Belle

LAMB
Yes . any handsome princes, and they're OURS!!

DAME
The **real** world is that if we don't get back to work, we'll have no money, we'll all starve . and we'll never have a house like my sister in England, with a swimming pool and room for a pony. Come on girls, back to work!

*C & L grudgingly return to the café. Dame goes inside café. C & L sit at another table & do their nails etc.
Madame Tricot enters and waits to be served, the two sisters look up, but do not move.
Belle goes to serve her.*

BELLE
Good day, Madame

M. TRICOT
Good day, my dear

BELLE
What can I get for you? A coffee perhaps?

M.TRICOT
I'd like a luke-warm coffee and a slice of stale chocolate cake

BELLE
But we can't serve you that!

M.TRICOT
Why not, that's what I got yesterday!

This script is licensed for amateur theatre by NODA Ltd to whom all enquiries should be made.
www.noda.org.uk E-mail: info@noda.org.uk

BELLE

Oh I'm sorry Madame

M.TRICOT

It was those lazy sisters of yours ò . they're losing you lots of customers, you know

BELLE

Yes, Madame (*she looks across at her sisters & shakes her head*). I'll get you a nice hot coffee and some fresh chocolate cake . on the house, of course (*Belle goes inside the café*)

*There is a bit of a commotion from some girls at the rear of the stage as Jean-Claude enters – he is very popular with the young ladies – and knows it
C & L realise that Jean-Claude is approaching*

C & L

Jean-Claude!

They jump up quickly, tidying their hair & clothing

CHARD

He's mine!

LAMB

He's mine!

J-C stands by a café table and clicks his fingers. The two sisters run to him – one moves his chair for him to sit down, the other tucks a napkin under his chin. They both flutter and flirt

C & L

Good day Jean-Claude

LAMB

My name's Lambrini . but you can call me Little Lamb

CHARD

My name's Charday . you can call me anytime

The girls are trying to impress J-C, but he is so self-obsessed, he doesn't notice

J-C

Coffee!

C & L

How would you like it, Jean-Claude

J-C

Strong, dark and rich . rather like myself

CHARD

I'll get it, you stay here ò . (*thinks*) No **you** get it . **I'll** stay here

LAMB

Get Belle to get it and we'll both stay here

C & L

This script is licensed for amateur theatre by NODA Ltd to whom all enquiries should be made.
www.noda.org.uk E-mail: info@noda.org.uk

BELLE!

*Belle comes out of the café – she sees J-C (oh, no!)
J-C spots Belle, he stands, removes his table-napkin and walks forward to stand next to Belle. He is slimy, but he thinks he is sexy*

J-C
Ding Dong Belle!

BELLE
(cringing) Jean-Claude ò . how are you today?

J-C
As always, I'm handsome, debonair, positively dashing ò

BELLE
ò . modest and shy?!

J-C
Belle, my beautiful little pumpkin

BELLE
Pumpkin??!

J-C
Belle, this is your lucky day! Not only do you have my much-esteemed presence at your down-market little café -

BELLE
Down-mark-

J-C
- but you will be attending a special celebration party that I am holding tonight at my larger than average mansion

CHARD
What about me?

LAMB
And me?

VILLAGE GIRLS
What about us Jean-Claude?

J-C
Popularity . sometimes it is a curse. I have always had stunning good looks, a wonderful personality and an incredible array of talents, but since winning ~~£~~Pop Idol'ò .

Village Girls scream & run up to J-C with autograph books

J-C
ò . since winning ~~£~~Pop Idol~~q~~(*swings hip & points at girls to scream*)

Village Girls scream again. One girl is so overcome, she faints.

J-C
I'm more popular than ever. And getting richer by the minute . but it's only money, and I have far more than I need. I'm lucky you see . I'd never have to spend thousands on plastic

surgery . how can one possibly improve on perfection?

VILLAGE GIRLS

Oh, Jean-Claude!

J-C

And which one of you lucky girls wants to come back to my place to wash my hair ò ..
(*shakes head back & ruffles hair*) because I'm worth it.

All of the girls (except Belle) rush forward to J-C

J-C

What about you, Belle? You know you want to run your fingers through my hair

BELLE

Jean-Claude, when you wash your hair, it causes such an oil slick, that we have to have Friends of the Earth on standby!

J-C

Oh, Belle . you're such a tease ò . if I wasn't so utterly gorgeous . I might think you meant it!

SONG %Don't Need Anything but Love+(%Chicago) . Jean-Claude.

Slight parody:- the word %love+is replaced with %me+

Tonight, then, everyone! Be there, or be ò . er ò you know. See you later!

J-C exits. Girls look longingly after him

CHARD

Isn't he charming?

ALL

Charming! (sigh)

LAMB

Ravishing!

ALL

Ravishing! (sigh)

GIRL 1

Fascinating!

ALL

Fascinating! (sigh)

GIRL 2

Captivating!

ALL

Captivating! (sigh)

BELLE

Nauseating!!

ALL

Nauseating (sigh) NAUSEATING??!!

BELLE
Yes, nauseating.

Belle goes into the café

M.TRICOT
Give me some Sea-Legs. at my age, you're grateful for anyone . .

Girls exit, discussing what they will be wearing tonight. Father enters, he looks down-trodden & weary. He has Gigi with him

LAMB
Papa, Papa, I'm going to a party tonight. Pleeeeease can I have a new dress?

CHARD
Papa, Papa, I need a new dress . don't waste money on her, she's a lost cause . I must, must, must have a new dress!

PAPA
I'm sorry girls, but you know I don't have any money. I've walked for miles today, looking for work . but I've found nothing. . I can't even support my own family . I'm a failure .

C & L
(heartless) Too right!

Dame comes out of café

CHARD
Mama! We've been invited to Jean-Claude's party tonight .

LAMB
- and we need new clothes

CHARD
- and a hair-do

LAMB
- and a manicure

M.TRICOT
(aside) and a face-lift?

C & L
Please, please, please, pleeeeeeeeeee!!

PAPA
I'm sorry dear, but I didn't find any work today . so we still don't have any money

DAME
But this is a chance we cannot afford to miss . to get one of our daughters married off to Jean-Claude .

CHARD
Good looks!

DAME

This script is licensed for amateur theatre by NODA Ltd to whom all enquiries should be made.
www.noda.org.uk E-mail: info@noda.org.uk

Lots of money!

LAMB

Great personality!

DAME

Lots of money!

CHARD

Nice body!

DAME

Lots of money!....

We need to raise some cash somehow - so the girls can look their best for the party
(*she looks around for inspiration*)

CHARD

We **could** sell the old nag ò .

LAMB

(*looks at Dame*) Nah! We can't have more luck selling the horse!

Reaction from Dame! Horse is worried

PAPA

We can't sell Gigi . she's part of the family

M.TRICOT

And better looking than most of them

DAME

We probably wouldn't get much for her . she's not as strong as she used to be

LAMB

She can make a fair few cans of dog food though

Gigi's knees are knocking now

CHARD

Dog food? This is France, remember . she can make a whole load of steaks and some nice horse-burgers

Gigi collapses/faints at this final suggestion

PAPA

(*runs over to comfort Gigi*) We will NOT be selling Gigi at any price. Come on old girl . up you get. Take no notice of those two ò

Papa helps Gigi to her feet. Sisters are talking to Dame and are side-on to audience, with their backs to Gigi's hind legs.

PAPA

ò . they're mean and selfish ò . in fact they deserve pulling down a peg or two

Gigi gives a look to the audience, then kicks out her right back leg – knocking Lamb to the ground, then her left back leg – knocking Chard to the ground. She looks at audience, pleased with herself. Sisters are horrified and screaming in protest, Papa is laughing quietly to himself

This script is licensed for amateur theatre by NODA Ltd to whom all enquiries should be made.

www.noda.org.uk E-mail: info@noda.org.uk

LAMB

You'd pay for this, you old nag!

CHARD

I'd be contacting Pedigree Chum as soon as I get up off this floor!

Papa strokes Gigi – pleased that she has stood up to his mean daughters

DAME

Come along girls . up you get

The girls get up, rubbing their bruised bottoms and scowling at Gigi

DAME

We've made a decision . we're going to have to sell the café ò .. we'd sell the café so that the girls can look their best for the party

PAPA

Sell the café? But it's all we have ò ò

Sisters have already disappeared into the café, returning with a 'For Sale' sign. Belle follows them out

BELLE

What's going on? Oh hello Papa (*she kisses him*)

CHARD

We're selling the café ò

LAMB

So that we can have new clothes for the party

BELLE

You can't do that . it's all we have

DAME

Think of it as an investment . if one of you marries Jean-Claude . we won't need to work any more

BELLE

Well I for one am definitely not marrying him

CHARD

As if **you'd** get a look-in

LAMB

Not with **us** as competition

PAPA

I'm still not sure about selling the café ò .

BELLE

We will **not** sell the café, Papa. I have an idea. I will sell my book collection . that should raise enough money for the party

PAPA

But Belle, you treasure those books. Ever since you were a small child you have scrimped and saved to buy each one

BELLE

Yes Papa, I know. But it is what I want to do. I will visit Monsieur Conteur at the book-sellers . he is always asking me whether I will sell my special books

Belle goes into the café, taking the 'For Sale' sign with her

CHARD

It's about time she sold those stupid books

LAMB

Yeah õ they haven't even got any pictures in

PAPA

You are very lucky to have such a kind sister . you could learn a lot from her

CHARD

Book us in at the beauty parlour Mama

C & L

We're going to a party!

Scene 2 A Woodland Clearing

Prince Louis & Jacques enter. Prince strides ahead, Jacques is struggling under a large, overloaded rucksack

JACQUES

Prince Louis, I know you had a great time in your Gap Year on the Raleigh Challenge . but did you have to insist that we walk all the way home now that you're **finished** at University?

PRINCE

Don't be such a wimp, Jacques!

JACQUES

Unfortunately, I don't get to travel as lightly as you. Can we have a rest? *(they sit down for a rest, Jacques gets out a drink, the Prince takes it ...)* Are you looking forward to getting home again Prince Louis?

PRINCE

Yes. Except that I will now be expected to settle down to my responsibilities - and of course, find myself a wife.

JACQUES

I bet that Countess Cruella is still very interested

PRINCE

She's scary!

Countess Cruella suddenly appears stage left

COUNTESS

Prince Louis! We meet again

JACQUES

(jumps up) Wow!! Now that IS scary!

PRINCE

(jumps up) Countess Cruella where did you come from?

COUNTESS

I heard that you were on your way
For far too long you've tarried
You'd not be straying far from home
Once that we are married

PRINCE

Married?!

JACQUES

Did I miss something? Like - the stag night?!

PRINCE

You missed nothing. I am NOT getting married

COUNTESS

Many, many years ago,
Our parents made a vow
That you and I would one day wed
My Prince, that time is now

PRINCE

That is ridiculous! My parents made no such promise

COUNTESS

A promise made, must be upheld
To break it is unwise

PRINCE

No promises were made to you

COUNTESS

I will not hear these lies!
(she moves back over to stage left and continues to talk to audience. Prince & Jaques mime talking to each other)
Prince Louis, he **will** be mine
Just watch and you will see
The villain of this pantomime
Is here my dears . it's me!
(hopefully a bit of booing & hissing. Countess exits)
Ha ha ha ha ha!

JACQUES

So why didn't you mention it?

PRINCE

Mention what?

JACQUES
The wedding

PRINCE
There IS NO WEDDING!

JACQUES
So what was ~~the~~ Moaning Myrtle~~whining~~ on about?

PRINCE
I've no idea . but she's gone now, thank goodness.

JACQUES
But don't you think it was a bit spooky . the way she just suddenly appeared like that? You're the intelligent one . how do you explain that?

PRINCE
University doesn't teach you stuff like that. I learned how to do lots of other important things . like . drink!

JACQUES
(*holds head*) oooh, don't remind me!

PRINCE
How to dance (*does a few moves*)

JACQUES
So that's what you call it! . but did you learn anything that could perhaps justify the expense of your higher education?

PRINCE
I learned that the sun revolves around the earth . or is it the moon? . or something .

JACQUES
Oh bravo! Money well spent . student loan, overdraft, tuition fees . worth every penny!

PRINCE
Jacques! I'm only joking! I learned a lot. We had a good time though, didn't we? Still, it's good to be back - I've really missed this old forest . the sights, the sounds, the smells .

JACQUES
. the wild animals . the wolves . the bears . (*he looks around, nervously*)

PRINCE
Don't be such a scaredy-cat, Jacques! I've spent many a happy hour in this grand old forest

JACQUES
Well, I don't like wild animals, so if you don't mind, we'd get a move on now . before the grand old forest sneaks up on us and bites us on the backside

PRINCE
Jacques, this is a family show . you can't say ~~backside~~

JACQUES
Can't I?

PRINCE

No

JACQUES

Oh. What about ~~bottom~~?

PRINCE

What about ~~bottom~~?

JACQUES

Can I say ~~bottom~~?

PRINCE

No, no, you can't say ~~bottom~~

JACQUES

~~Bum~~?

PRINCE

I beg your pardon?

JACQUES

~~Bum~~ can I say ~~bum~~?

PRINCE

Oh no, you certainly can't say ~~bum~~

JACQUES

So ~~bum~~s out

PRINCE

~~Bum~~s is most definitely out

JACQUES

Aah, so basically, ~~backside~~ ~~bottom~~ and ~~bum~~. they're all out?

PRINCE

~~Backside~~ ~~bottom~~ ~~bum~~. all out

JACQUES

Fine! Well I won't be saying any of them, then

PRINCE

Neither will I. ~~o~~ .. ~~we~~ lost track, where were we?

JACQUES

I know! We were trying to get out of this wild and scary forest, before something wild and scary bites us on the ~~o~~ er ~~o~~ . leg

We hear Belle and Dame talking

PRINCE

Someone's coming! Quick, hide behind this tree

JACQUES

May I ask why?

This script is licensed for amateur theatre by NODA Ltd to whom all enquiries should be made.

www.noda.org.uk E-mail: info@noda.org.uk

PRINCE

õ sounds like girls õ it would be a wheeze to jump out and surprise them

JACQUES

Not much about **maturity** on the syllabus, then?

PRINCE

What? õ .. of course not! Come on!

Prince & Jaques hide. Belle and Dame enter

BELLE

I've always loved this part of the forest, Mama, it's so peaceful and quiet

DAME

(very loudly!) Hello everyone!

AUDIENCE

Hello Dolly!

Dame throws sweets

DAME

Yes, peaceful and quiet, I know what you mean. Anyway, we must hurry back to the café! Now that we have the money from selling your books, we can make sure that we all look our best for Jean-Claude's party

BELLE

I know that you mean well, but I wish you wouldn't keep trying to get me married off to that awful Jean-Claude õ

DAME

But he so obviously fancies you õ and he's very rich õ ..

BELLE

But he's such an oaf õ . and money isn't everything.

DAME

It'd do for me õ . I've often wondered about trading your father in for a rich toy boy

BELLE

Mama! You know you don't mean that! I want to marry for love õ õ someone kind, intelligent, handsome, sensitive õ

J-C enters

J-C

Ah, Belle, talking about me again, I hear!

He leers at Belle in a way that he thinks is attractive but isn't

BELLE

I was NOT talking about YOU

J-C

You cannot fool me, Belle. I know how flattered you must be that I have chosen you from all

This script is licensed for amateur theatre by NODA Ltd to whom all enquiries should be made.

www.noda.org.uk E-mail: info@noda.org.uk

of the other girls who throw themselves at my feet

BELLE

Eughh! You are disgusting, Jean-Claude

J-C

Aha! Playing hard to get, eh? Of course, you will be begging me to marry you before this day is out

BELLE

I don't think so ò . Come on Mama

DAME

Marry? ò ò Belle, don't be too hasty dear. Think of his good points ò

BELLE

(thinks for a second) Can't think of any. I'm off ò .

Belle goes to leave, J-C grabs her arm

BELLE

ò . let go of me!

J-C

You know I always get what I want

BELLE

Not this time you don't!

Jacques appears from behind the tree

JACQUES

Let go of her, you big bully!

J-C pushes Jacques to the floor

J-C

Push off small fry . this is a man's world

Prince appears from behind tree

PRINCE

Unhand that maiden at once, you blackguard!

Dame goes to look behind the tree – to see if there are any more men!

J-C

Back off *(looks Prince up and down)* ò ò college boy
Before you two so rudely interrupted, my fiancée and I were just having a private chat

BELLE

I am NOT *(she stamps on J-C's foot)* your fiancée

J-C hops around in pain

JACQUES

I think we may have disturbed a loversquiff

Belle walks angrily towards Jacques

BELLE
We are NOT õ õ

Jacques jumps up quickly, backing away from Belle

JACQUES
õ . they are NOT õ .. Shall we just leave now?

Prince walks forward to talk to audience

PRINCE
I'm not sure that I want to leave õ she is beautiful õ I have never met anyone quite like her
õ . and such spirit õ .

JACQUES
Excuse me, Your Highness . this isn't Shakespeare . she can hear everything you're saying

PRINCE
I don't care I want her to know õ I want you to know how I feel

BELLE
Oh no, not another one!

PRINCE
I must know your name

J-C
You do not need to know her name. Belle is mine! Doh!

PRINCE
Belle . what a beautiful name.

JACQUES
Yes . has quite a ring to it õ .. Shall we make tracks now, Your Highness

DAME
Your Highness? Is that Your Highness as in **Prince** Your Highness?

PRINCE
Yes, Madam

J-C
I don't care if you're the King of France. You cannot have Belle

PRINCE
But she doesn't seem that interested in you, sir

J-C
She's young . she doesn't know what she wants
(Belle looks aghast)
But I can tell you she wants a real man, not some effeminate, spoon-fed, aristocratic dandy

Prince changes from slightly camp stance to butch pose

PRINCE
This script is licensed for amateur theatre by NODA Ltd to whom all enquiries should be made.
www.noda.org.uk E-mail: info@noda.org.uk

However, she may want someone with a little more sophistication than yourself

J-C

What good is sophistication when I could beat you to a pulp with one hand behind my back?

J-C puts one hand behind his back

PRINCE

Says you! And I venture I could beat you to a pulp with both hands behind my back

JACQUES

Louis??!!

BELLE

HOW DARE YOU! I am not some prize to be fought over by foolish boys. Come along mother . Love suddenly gone off this part of the forest

DAME

Oh but Belle! That one's rich Oh .. and that one's royal AND rich Oh .. *(big sigh, shakes head)*
where did I go wrong?

Dame exits after Belle. The 'boys' continue their argument in the background, slowly exiting the stage as they do so. The Fairy enters from Stage Right

FAIRY

I promised a tale of love and hope
But it's more like a television soap
Jealousy, violence . Love ignored
Except Jean-Claude, who loves - Jean-Claude!
(Countess enters from Stage Left)
The Prince should fall in love with Belle

COUNTESS

That's not the tale I'm here to tell
You stupid fairy! . Can't you see?
The Prince will fall in love with me

FAIRY

Ah, Countess Cruella I might have guessed
That you'd be here to spoil our quest

COUNTESS

Your quest will never work, my dear
Not now Countess Cruella's here
The Prince will fall in love with me
So get back on your Christmas tree!

FAIRY

You think your evil ways will pay
But I have good friends here today
They want the Prince to marry **Belle**

COUNTESS

I could turn **them** to toads with one small spell!
Ha ha ha ha ha!

Countess exits

FAIRY

Ignore her threats and work with me
Goodness will triumph - wait and see!

Fairy exits

Scene 3 The Beauty Parlour

(See Additional Notes for details of props for this scene)

Music Instrumental %Keep Young and Beautiful+

Sisters on stage, probably wearing dressing gowns or something similar

LAMB

Madame Botox's Beauty Parlour . it's very posh

CHARD

I don't know why Belle didn't want to come . still, never mind, more money to spend on us!
Madame Botox!

Madame Botox enters

C & L

Make us beautiful!

MADAME

How much time do we have? *(aside)* Weeks? Months?

LAMB

The party's tonight

MADAME

Tonight???! Oh well, I do like a challenge! I know - we'll start by warming up with a few exercises ò .. 5, 6, 7, 8, reach and stretch and reach and stretch and ò .. Madam Jolly . you are not reaching and stretching ò

DAME

The only reaching and stretching I usually do - is reaching for a beer and stretching the truth to my husband ò .

MADAME

Give her a hand, girls ò .. and stretch those arms ò and stretch those arms ò .. and stretch those arms ò ò . *(she turns around)* and aaaah!

*With a girl each side, each time Madam says stretch – the girls pull on Dame's arms.
Her arms keep stretching They are false arms!*

DAME

What have you done to me?

CHARD

At least you'll be able to reach the top shelf in Asda, now!

MADAME

This script is licensed for amateur theatre by NODA Ltd to whom all enquiries should be made.
www.noda.org.uk E-mail: info@noda.org.uk

Oh dear *o* . I think we'd forget the exercises. Take a seat, my dears. And you, Madam, I think you would like the steam chamber. Come along!

Madame Botox leads Dame to back/off-stage into the steam chamber.

C & L sit opposite each other at a dressing table, with a central "mirror" – it's just a hollow frame. They peer forwards at what they think is their reflection – but they are actually looking at each other

M & L

Ooooh . I look a bit rough today!

Sisters "mirror" each others movements

LAMB

*(picks up a tub of cream) Oooh Dream Creamq(reads) o the perfect complexion in minutesq
o we'd try that (she scoops a dollop of cream and puts it through the mirror onto Chard's right cheek – Chard is so shocked, she just sits there. Lamb takes another scoop and slaps it onto Chard's left cheek. She picks up another tub – reads) 'this beats the rest . increase your chestq o . We definitely need that one (she moves around to stand next to Chard – pulls out her top and squirts the foam down her front – laughing, she returns to her chair)*

CHARD

(angry now. Wipes face. Picks up a tub – reads) For beautiful hair o because we careq(she stands behind Lamb and splats the cream onto her head – they are about to beat each other, when Madame B returns)

MADAM

Oh, I see you've sampled some of our wide range of beauty products . I'd add it to your bill.

Now, ladies, I think we will attend to the hair. Girls!

(The two trainee hairdressers, Chelsea and Tiffany, enter)

Ah, Chelsea! Tiffany! . these two ladies need a beautiful hairdo for a party tonight

CHELSEA & TIFFANY

Yes, Madame!

Chelsea & Tiffany start to wash the sisters' hair

CHELSEA

Have you been on holiday?

CHARD

No, I .

CHELSEA

That's nice! Lean back *(leans her back over sink to start to wash hair)* I went to Majorca . have you been?

CHARD

No, but .

CHELSEA

Oooh you want to go . sun, sea, Sangria! Is the water ok for you?

CHARD

It's a bit cold .

CHELSEA

Gooō ooō d. Do you like Sangria?

This script is licensed for amateur theatre by NODA Ltd to whom all enquiries should be made.

www.noda.org.uk E-mail: info@noda.org.uk

CHARD

Yes, I .

CHELSEA

I'm a Bacardi Breezer girl me . three or four of them and I have to lie down . ooh I am a one! Conditioner?

The focus now switches to the other two

TIFFANY

Aren't men just the pits?

LAMB

Well some of .

TIFFANY

I've just broken up with my boyfriend. Lean back. Have you got a boyfriend?

LAMB

No, but .

TIFFANY

I bet your boyfriend's nice, not like mine . is the water ok for you?

LAMB

I haven't got .

TIFFANY

I bet he doesn't treat you like dirt like my boyfriend did

LAMB

I haven't got .

TIFFANY

(starts to cry) ooooh I miss him *(exits wailing)*

CHELSEA

(exits after Tiff) Oh Tiff. Don't cry. We'll go to Zanzi *(replace with local nightclub)* tonight ò

M & L

What about my hair?

MADAME

What on earth is going on? CHELSEA! TIFFANY! Ooh those girls!

(Madam wraps towels/turbans around the sisters heads)

Never mind, ladies, we'll finish the hair later. *(to Lamb)* I think you like a massage!

LAMB

Oooh, a massage!

MADAME

You'll need to undress ò *(L starts to undress 'sexily' humming The Stripper' tune)*

BEHIND the screens! *(L goes behind the screens)*

Take off your clothes and lie on the massage couch. My Swedish masseur, Sven ò

Lambrini's head appears immediately from behind the screen

LAMB
Sven?!

MADAME
ō .. will be here to give you a massage. Just relax . and think of Ikea

CHARD
But what about me?!

MADAME
Oh, I have something VERY special for you

CHARD
(excited) Ooooh! What is it?

MADAME
A nice bikini wax

CHARD
But ō .. doesn't that ō . hurt?

MADAME
Ye..e..e..s. But Tarquin **will** be gentle with you! *(calls)* Tarquin!

Tarquin enters with a bucket – he is stirring the contents with a spatula

TARQUIN
Yes Madame! Smooth and hot . and ready to go!

MADAME
A little *(indicates 'down there')* tidy-up for this lady, please Tarquin ō .. *(to Chard)* just pop behind the screen, dear ō ō and get undressed

Chard goes behind the screen, then calls out -

CHARD
I'm not sure about this!

Tarquin goes behind screen

MADAME
You'd be fine, dear *(peeps behind screen, then to audience)* That's the wax going on ō ō alright, dear?

CHARD
(tentatively) Ye..e..e..e..s

MADAME
(peeps behind screen, then to audience) Just drying now ō ō .. alright, dear?

CHARD
Ye..e..e..e..s

MADAME
(peeps behind screens, then to audience) Nearly ready ō ō . alright dear?

CHARD
Ye..e..e..e..s

MADAM
(peeps behind screens) Here we go! *(indicates to audience to put fingers in ears)*
ō .. alright, dear?

Pull apart a large strip of "Velcro" for sound effect!

CHARD
YeeeAAAAAAAAAAH!!!!!!!!!!!!

MADAME
Ooh, I think it might be time for my tea-break! *(exits)*

Sven appears and moves the screens back, so that the audience can see what is happening. Lamb 'lies' on the couch – but false legs take the place of her own

SVEN
I am Sven . best masseur in Sveeden *(The massage starts off gently, with Lamb enjoying it)*
Is good, ya?

LAMB
Mmmmmmm!

SVEN
More stronger, ya?

LAMB
Yaaaa!

Sven starts to bend legs further – gradually the legs are bent and twisted in all directions, with Lamb screaming to suit, until she collapses, exhausted

Madam returns

MADAME
Did you enjoy that? Ooh, look she's so relaxed, she's fallen asleep! You can go now, Sven . find Chelsea and Tiffany . they need to finish the ladieschair
(Sven moves screen across, then exits)
ō Mademoiselle Lambrini! Mademoiselle Chardonnay! Sorry to disturb you, my dears . but we really do need to be attending to that hair before you go ō ..
(C & L stagger out from behind the screens – C with legs crossed, L with legs like jelly)
ō .. that way my dears! Chelsea and Tiffany will be at your disposal, offering all of the latest styles ō . *(Madame indicates for C & L to exit to wings. She then starts to 'tidy up' – moves the couch & screen back, so it's not blocking st.R entrance)*

DAME *(from wings)*
Madame Botox! It's getting hot in here!

MADAME
Oh no! I forgot about Madame Jolie! *(pulling Dame, enclosed in steam chamber, from the wings – steam pours out of neck of chamber – Dame looks very pink)* No pain . no gain, dear! Steam will draw out the impurities and excess water, leaving a purer, slimmer body.
Let's have a look ō *(she opens the front of the chamber – we see a very shrunken Dame's*

This script is licensed for amateur theatre by NODA Ltd to whom all enquiries should be made.

www.noda.org.uk E-mail: info@noda.org.uk

bodyit is a dummy, as the Dame's real body is behind a false back) õ .. oh dear!

DAME

What's the matter? What's happened to me? Am I not purer and slimmer?

MADAME

õ . you **are** a bit slimmer õ . But I think we'd reverse the process a little õ . *(she closes door & fiddles with a few dials and buttons)*

DAME

Ooooooh! Ooooooh! Get me out of here! What's gone wrong?!

MADAME

(fingers crossed behind her back) Everything's fine, Madame Jolie. Only the best treatment at my parlour *(very cautiously opens the doors – Dame is back to normal – she breathes a sigh of relief)* of course nothing ever goes wrong. Phew!

Dame gets out of chamber

Chardonnay & Lambrini scream off-stage, then run on stage. They are sporting very "bad hair" – perhaps bright green, or maybe bald?

DAME

(in shock) Girls!

Sisters exit quickly, followed by Dame

MADAM

GIRLS!!!!

Chelsea & Tiffany sheepishly enter from the wings

SONG "Beauty School Dropout" - Mme Botox & the Beauty Parlour Girls

Scene 4 A Lane in the Village

Chardonnay and Lambrini enter, still sporting their "bad hair"

CHARD

How can we go to Jean-Claude's party looking like this?

LAMB

He's not going to give me a second glance, now

CHARD

Well I don't know about that . he could hardly miss you, could he?

LAMB

Probably not. Anyway, I thought you said that was the place used by Pamela Anderson?

CHARD

No . I said CLIVE Anderson

Belle enters with a couple of children

CHILD 1

This script is licensed for amateur theatre by NODA Ltd to whom all enquiries should be made.

www.noda.org.uk E-mail: info@noda.org.uk

Read us a story Belle!

CHILD 2

Yes, Belle! Please read to us!

BELLE

Well I've just sold my favourite books . but I can **tell** you a story ò .

CHILD 1&2

Yes please!

Belle notices her sisters

BELLE

Chardonnay! Lambrini! Erm ò . What on earth happened? (*indicates to their heads*)

CHARD

We ò er ò wanted something different

BELLE

Well it IS ò ò different

LAMB

It's YOUR fault!

BELLE

MY fault?

LAMB

Yes, YOUR fault! If you hadn't sold your books and given us that money . we wouldn't have visited Madame Botox's Beauty Parlour this morning ò .

CHARD

YES . YOUR fault! If we hadn't gone to Madame Botox, we would still be as beautiful as ever

BELLE

ò .. I sold my books for **this**?

CHARD

See . she **admits** that it is her fault . lets get her!

Belle jumps side to side to avoid Chard. Then she runs behind a tree or off to wings. Child 1 points up, Chard looks up, child 2 stamps on her foot. Chard hops around & falls over. Lamb bends to see if she is ok, child 3 kicks her bottom, so that she falls over

J-C enters, with his personal assistant. She takes notes

J-C

ò and music . yes, we must have music. Girls like a man who can dance ò and can I dance?! (*swivels hips*) Just **another** of my many talents!

PA sighs and flutters eyelashes

CHARD

It's Jean-Claude!

LAMB
Great! (*tidies herself up*)
CHARD
The hair?! (*aaaah!*)

LAMB
Hide!!

J-C
Hello girls (*notices hair*) where's your sister? Not at your hairdressers, I hope (*laughs at his own little joke*) oh sometimes I'm so witty . I take **myself** by surprise

CHARD
She's over there

LAMB
And THIS is HER fault!

J-C
Ha ha - a good sense of humour as well? I like that in a girl! BELLE!

Belle reluctantly appears from behind the tree. The sisters are scowling at her

BELLE
Jean-Claude. What a nice surprise (*she is being sarcastic – he doesn't notice*)

J-C
Yes I am, aren't I? Like Christmas, Easter and summer holidays, all rolled into one!

BELLE
Especially summer holidays . you remind me of the sea

J-C
I know - because I'm wild, restless and romantic ò

BELLE
No, Jean-Claude . because you make me sick

J-C
But Belle . it can only be love-sickness, which I will cure tonight when you are in my arms . I presume I'd be having the first dance?

BELLE
I've no doubt you will, Jean-Claude . but it won't be with me

J-C
Belle, Belle ò .. how long can you deceive yourself? No-one has ever resisted my charms ò it's one of those impossible things ò .. I'm just irresistible ò .. can't be helped ò

CHARD
I'd dance with you Jean-Claude!

LAMB
(*pushes Chard out of the way*) No! I'll dance with you!

J-C
There are ò on the other hand ò . some people who can quite easily be resisted ò .

(indicating C & L)

BELLE

Yes, Jean-Claude . and YOU are one of them! How dare you be mean to my sisters!

J-C

But they're mean to you all of the time

BELLE

That's different

C & L

Yes, that's different

BELLE

(to sisters) Not nice, though

(Sisters look a little bit remorseful)

ō come along children . we'll go somewhere else for our story

Belle & children exit

J-C

She'll come around. That's girls for you . don't know their own minds. Anyway . must go and get ready . so I can be the host with the most

J-C exits. PA trots after him

CHARD

That's it! We've blown it with Jean-Claude . he's never going to marry me now

LAMB

Marry you? It was ME he was going to marry!

CHARD

We're going to have to try and focus on our good points . then he may not notice our hair

LAMB

We'll have to buy him a blindfold . THEN he might not notice our hair!

CHARD

Whenever I'm with you . I always end up getting into trouble ..

LAMB

You always used to get me into trouble when we were at school ō like that time I got detention because YOU were smoking

CHARD

YES . I was smoking - but it was YOU who set fire to me!

LAMB

Ye..e..s, but ō

CHARD

It's no good . I think we just have a personality clash

LAMB

Personality clash . what do you mean?

CHARD

I have one . you don't!

Lamb is just about to lay into Chard when Papa enters, he is holding a letter. Gigi is with him, loaded up with belongings

PAPA

Hello, girls, have you seen your mother? What happened to your hair?!

CHARD

Don't ask! Oh .. Mama was heading home

LAMB

Why Papa? What's the matter? Why is Gigi loaded up with your belongings?

CHARD

You're not leaving Mama, are you? You didn't find out about Rene from the Boulangerie?

PAPA

Who?

LAMB

Chard's gay!

CHARD

Whoops!

PAPA

I'm looking for your mother because I have received this letter from my brother in the mountains . he's offered me a job for the tourist season Oh the skiing starts soon

CHARD

... but you can't ski

PAPA

He owns a hotel, and wants help with the apres ski

LAMB

The whatski?

PAPA

Apres ski. When the skiers have been on the piste all day Oh

LAMB

Papa! You can't say that

PAPA

Can't say what?

LAMB

On the Oh you know Oh

CHARD

We usually say Oh on the pop. it's a bit more refined

PAPA

The piste - is the ski slope. After the skiers return from the SKI SLOPES, they like to be fed and entertained . and my brother has offered me the job. It's very good money Oh .

This script is licensed for amateur theatre by NODA Ltd to whom all enquiries should be made.

www.noda.org.uk E-mail: info@noda.org.uk

LAMB

Good money? Bye Papa! Off you go!

CHARD

Missing you already! . Make sure you bring lots of money back!

PAPA

I'd miss you, too! I'd better go now, it's a long journey through the mountains - and the weather is getting worse by the day . I'd go via the café . see if I can see your mother and Belle before I go

Papa exits with Gigi

LAMB

Come on, Chard . we might as well go home now . see if we can find a couple of nice hats before tonight .

*Chard & Lamb exit after Papa
Countess enters, stage left*

COUNTESS

Are you enjoying yourselves? . Well we'll soon put a stop to that!
I can't be doing with good and nice
I hate things that are twee
This story needs an evil twist
And I think that's down to ME!
I'm getting very angry, now
The prince, he should be mine
But all he talks about is Belle
And how she's fit and fine
He says he really loves her
When he should be loving me
She's ruining my wedding plans
But she'll not win . you'll see
Ha ha ha ha ha

Countess exits

Scene 5 The Castle of Prince Louis

Music Instrumental for Courtiers Dance.

JACQUES *(pushing forward to interrupt dancers)*

You're not still doing this old-fashioned rubbish, are you? *(signals for 'modern' music & starts to do some sort of dance)*

Teenage courtier pulls him aside.

Second teen courtier signals for music to stop, then gives the "ok" for 'their' music to start

Music - Teens modern dance (any up-to-date pop song)

JACQUES

Not bad! What did you think, Prince Louis?

This script is licensed for amateur theatre by NODA Ltd to whom all enquiries should be made.

www.noda.org.uk E-mail: info@noda.org.uk

(Prince is 'miles away')

ō . Prince Louis? ō ..

PRINCE

Oh, sorry, Jacques ō . I was thinking about ō .

JACQUES

Let me guess ō ..Belle? Why don't you give her a ring - get it? Bell? . ring? ō ō oh, please yourselves ō ..

PRINCE

We can't ring anyone . the phone hasn't been invented yet

JACQUES

So we can't text either?

PRINCE

No

Courtier teenagers in a state of panic

Countess enters – unnoticed

COUNTESS

The Prince has spurned my love for him

But how can he resist?

I'm here to give him one last chance

I'll show him what he's missed

My charming smile, enduring looks

He'll soon be mine, it's true

And we'll be making wedding plans

Before this day is through!

Prince notices Countess

PRINCE

Ah, Countess Cruella what are you doing here in my palace? I don't recall having invited anyone today

COUNTESS

Love needs no invitation, dear

PRINCE

Love? What do you mean?

COUNTESS

You and **me**, my darling Prince

The future King and Queen

PRINCE

I don't love you . I never have and never will. I am in love with Belle

COUNTESS

Tut tut, my dear, please think again

You have but one last chance

Countess Cruella and Prince Louis

The ~~£~~Posh and Becks of France!

With all your money, and my good looks

We'll make a handsome pair

This script is licensed for amateur theatre by NODA Ltd to whom all enquiries should be made.

www.noda.org.uk E-mail: info@noda.org.uk

Then half the kingdom would be mine ò erò ours

Reject me . **if you dare!**

PRINCE

I dare, my dear Countess Cruella for I could never marry you in a million years. How many times do I have to tell you that I love another?

COUNTESS

Belle . how I **despise** that name

You choose **her** over **me**?

My Prince, you will regret that choice

For all eternity

JACQUES

I have to say, I can't blame Prince Louis ò . Belle is ò

COUNTESS

So, tell me, scrawny servant-boy

Before I cause you harm

Why choose Belle instead of me?

JACQUES

Beauty? ò .. grace? ò .. charm?!

Courtiers laugh

COUNTESS

Be quiet! Ugly shower of fools!

(Countess is very angry casts a spell- thunder & lightening effects. The spell takes the courtiers' voices- they cannot speak)

That's better! Now to you

A final chance to make me yours

And make our dreams come true

PRINCE

What have you done to my courtiers? I demand that you give them back their voices! And as for you . you are a wicked, horrible woman and **no-one** could **ever** love you!

COUNTESS

So, no-one could ever love me, you say?

So there'd be no wedding feast

And who will love Prince Louis

When he's turned into a BEAST?

Countess casts spell – Prince turns into a beast (see Additional Notes for staging ideas)

COUNTESS

Ha ha ha ha *(exit)*

The Prince is now a Beast. The Beast roars

Courtiers are horrified – but still unable to speak. Fairy enters

FAIRY

Oh no! Too late! And no mistake

This evil spell's too strong to break

What wicked forces have been here?

They are too strong for me, I fear

This script is licensed for amateur theatre by NODA Ltd to whom all enquiries should be made.

www.noda.org.uk E-mail: info@noda.org.uk

Courtiers try to speak to Fairy – but still no voices

FAIRY

The first spell I can break, it's true
Your voices will come back to you

Fairy waves her wand – the courtiers all begin talking at once. The Beast growls – the courtiers scream.

Jacques is very frightened of the Beast, and is hiding behind someone – he ventures out a little to speak ...

JACQUES

B b but what about the Prince? You must be able to do something?

Beast growls – Jacques runs back again

JACQUES

Aaaaah! I'm sorry Prince Louis . . . but you know how I feel about wild . . . scary . . . things

FAIRY

I cannot give the results you seek
But I can allow the Beast to speak
(waves wand)

BEAST

What . . . has . . . happened . . . To . . . me?
(Beast growls angrily at courtiers – they retreat back further)

FAIRY

A Beast forever, is your curse
I cannot make the spell reverse
But here's the plan that I propose
If you will take this magic rose

BEAST

MAGIC . . . ROSE?! WHAT USE IS THAT

JACQUES

(A bit braver, now) Master . . . you must listen to the Rose Fairy . . . it may be your only hope

Beast growls at Jacques, who backs away again

FAIRY

A rose, it is a lovely flower
But this rose holds a special power
It is possible . . . I will explain
To make you human once again

BEAST

THEN DO IT! DO IT NOW!

FAIRY

This rose is beautiful to the eye
But slowly it will fade and die
Each petal falling, one by one
But before the final petal's gone
You must find a love that's true

A girl must pledge her love to you

BEAST

Don't be ridiculous, you stupid fairy (*he takes the rose and throws it to the floor*) Get rid of this rose! What use is it? Look at me! No-one will ever love me looking like this (*to courtier girl*) Could YOU love me? (*girl runs away, shaking her head*)

Leave me alone, all of you! GET OUT! LEAVE MY CASTLE AND NEVER RETURN!

Beast growls loudly – courtiers run to exit stage. Jacques stays to pick up the rose. He exits, returning with the rose in a vase. Beast sits, head in hands

JACQUES

Please, Your Highness, look after the rose . it is the only chance you have of returning to your normal self. You may find a girl, if she knows that you are really a prince

FAIRY

You **are** a prince . but do not tell
Or this will break the magic spell

JACQUES

You mean that Prince Louis cannot reveal his true identity?

FAIRY

For this wicked curse to be released
The girl must love him as a beast

BEAST

Then I am doomed to stay like this forever. What girl will love a Beast?

JACQUES

Prince Louis . we must keep our hopes up (*he places the vase on the pedestal*). For as long as this rose lives . then your hopes must live also.

FAIRY

I cannot help you more than this
Now you must find a true love's kiss

Fairy exits

JACQUES

Louis ò

BEAST

I am NOT Louis . I AM A BEAST! NOW LEAVE ME ALONE . GET OUT OF MY CASTLE! . AND NEVER RETURN!

Jacques exits, head bowed. Soft music plays, as the Beast goes to the rose. He gently touches it, then drops his head in sadness. This poignant pose is frozen as the tabs close.

INTERVAL

ACT II**Prologue**

Fairy enters, Stage Right

FAIRY

Welcome back, ~~is~~ now Act two
The bit where all the dreams come true

Countess enters, Stage Left

COUNTESS

Depends if **nightmares** are your thing
For that is all **this** tale will bring
And as for you . you worthless peasant ò

FAIRY

She makes Simon Cowell seem pleasant
You should be sorry . in the least
For turning the Prince into a Beast

COUNTESS

It serves him right! And you will see
It doesn't pay to mess with me
You and this ugly little shower
Will soon be quaking in my power!
Ha ha ha ha ha!!!

Countess exits

FAIRY

We must be brave and stick together
So, back to the story . or we'll be here forever!
Believe Papa is a bit old and slow
He's managed to get himself lost in the snow ò ò ..

Scene 6 In The Mountains

Papa and Gigi are struggling through a snowstorm in the mountains

PAPA

Oh Gigi . I'm beginning to think this was a big mistake. We should have reached my
brother's by now . I think we're lost ò .. and it's getting dark ò .. I fear that we will perish if
we have to spend the night on this mountain ò

*Gigi drops her head down in sorrow- she feels guilty that she has not been a better guide.
Papa pats her head*

Don't worry, old girl . it's not your fault - Look! Up ahead! A castle . perhaps they will give
us shelter for the night?

Papa & Gigi struggle to the castle doors, and pull the bell - or if you cannot build castle doors into the set, use the wings, and have Papa mime "seeing the Beast"

BEAST

(off stage) WHO DISTURBS ME AT THIS HOUR?!!

Papa & Gigi look at each other – scared. Sound effect as Beast flings the doors open

BEAST

WHAT DO YOU WANT?

Papa gasps at the sight of the Beast. He trembles, but is rooted to the spot. Gigi runs off, terrified – but peeps in from the wings to watch what is happening.

PAPA

Gigi! Come back!

(then to the Beast) ò ò . somewhere to sleep, Sir ò .. shelter for the night ò ..

BEAST

ENTER!

Papa enters very tentatively

BEAST

YOU MAY STAY FOR THE NIGHT ò . IN FACT YOU MAY STAY HERE FOR ALL OF YOUR NIGHTS ò ò IN MY DUNGEON!

Beast slams the doors shut. Gigi doesn't know what to do. Look of panic to audience, then exits

Scene 7 The Village of Petits Pois

DAME

Oooh hello everyone!

AUDIENCE

Hello Dolly!

Throws sweets

Chard & Lamb enter – both are hung-over

CHARD

Shhhh! Keep the noise down!

LAMB

Ooooh! My head!

DAME

Oh dear! It's Wallace and Grommit! You two look a bit rough ò . even more than usual ò . A few too many alcopops at Jean-Claude's party, I presume?

CHARD

It was that glass of champagne ò . it didn't agree with me ò .

DAME

This script is licensed for amateur theatre by NODA Ltd to whom all enquiries should be made.

www.noda.org.uk E-mail: info@noda.org.uk

And I suppose the twenty-four Bacardi Breezers were OK then?

LAMB

Ooooh! *ō . I'd never drink again ō .. well not ~~at~~ student night at Zanzibar! (replace with name of local nightclub)*

CHARD

Student night? You're obviously a very **mature** student! You're closer to getting your OAP bus pass than your NUS card

LAMB

What?!.... Well **you** look like a movie star

CHARD

Oh, thank you!

LAMB

Shrek!

They are just about to fight – Dame splits them up

DAME

Girls! Girls! You have the manners and social graces of Bernard Manning. The idea of going to Jean-Claude's party was that you should pick up a rich husband *ō . why, even I got chatted up by that very nice antiques dealer ō .*

CHARD

Yes, he said he liked old relics!

DAME

Ooooh!

Jean-Claude enters, with girls in tow

J C

Hello girls! Where's your sister?

LAMB

Here I am!

CHARD

(pushing Lambrini out of the way) He means me, of course!

J C

No, no *ō ō* the one who **isn't** aesthetically-challenged *ō .*
(C & L are not sure whether or not they have been insulted)

ō ō .. my little ding-a-ling *ō ..*

(C & L look down at JC's trousers)

ō ō BELLE!

L & C

Oh, **Belle!**

J C

Where is she? She **was** a tease at my party . trying to hide from me all night *ō ..* I wanted to kiss her under the mistletoe *ō .*

This script is licensed for amateur theatre by NODA Ltd to whom all enquiries should be made.

www.noda.org.uk E-mail: info@noda.org.uk

Belle enters

BELLE

(to audience) I wouldn't kiss him under anaesthetic!

J C

Belle! You came to find me!

BELLE

Jean-Claude! I didn't expect to find you here ò ..

J C

Well, here I am! You've found me! How wonderful for you! Last night, I was flattered that you were making such an effort to be a challenge . most girls just throw themselves at me . not that you can blame them, of course *(he moves close to Belle – he thinks he is sexy)* Why don't you come back to my place?

BELLE

Is there enough room under **your stone**?

CHARD

We'll come back to your place, Jean-Claude . won't we, Lambrini?

LAMB

Yes, yes . you only have to ask

(silence)

CHARD

You only have to ASK

(silence)

DAME

Jean-Claude ò . I like my little girls to stay together ò ..

LAMB

Ugh! Not with Belle ò .

CHARD

No, we don't hang around with HER

DAME

ò .. Chard and Lambrini are very protective of their little sister ò

C & L

WHAT???! She's pathetic / we can't stand the little goody-goody ò .

DAME

ò . they won't let Belle come to your house **alone**

C & L

(penny drops) oooohh ò . of course not / we love Belle

J C

Alright, alright . I suppose they can come too. And by the way . **mansion** – I live in a larger than average **mansion** . not a **house** . image is everything ð .

DAME

Yes, sorry Jean-Claude, and what a lovely mansion it is too ð . my sister in England has a similar one . with a swimming pool and room for a pony

J C

Just the **one** pony? Mine is obviously substantially larger

BELLE

What? Your head? ð . I'll tell you what . you all go on ahead to Jean-Claude's larger than average mansionq I've just got a couple of things to do - I'll catch you up

L, C, DAME

OK! / Lead the way! / Onward!

J C

I thought you wouldn't leave Belle alone?

BELLE

I insist ð I really must start to be independent ð .. I can't be reliant on my big sisters forever ð .. go on now . I won't be long

All exit, except Belle

BELLE

Thank goodness they've gone!

(Gigi enters wearily) Gigi! Where's Papa? What has happened?

(Gigi hooves the ground a few times – Belle watches carefully)

You were travelling in the mountains? ð ð and the snow was heavy? ð . so you looked for shelter? ð .. and there was a beast in the castle? ð .. and he's taken Papa prisoner?

(Gigi nods)

(Belle speaks to audience) . and you thought Skippy was clever!

We must rescue Papa!

(Gigi scared – no, not me!)

But Gigi . you need to take me to the castle . I'll never find it on my own. Come on, old girl . we must leave as soon as possible!

(They exit – Gigi's eyes look up to heaven and she shakes her head)

J C enters – he has returned for Belle

J C

Belle! Belle! Where are you? I've come back for you! I'm all alone, and all yours ð . if you come out now, you can have a kiss ð

J C closes eyes & pouts lips. Countess enters

COUNTESS

Belle! Belle! That name again

That girl is driving me insane

First the Prince, and now this Dandyq

But **this** one might come in quite handy

J C

Oh ð .. who are you?

This script is licensed for amateur theatre by NODA Ltd to whom all enquiries should be made.

www.noda.org.uk E-mail: info@noda.org.uk

COUNTESS

Who I am . you need not know
 But if you want Belle to be your beau
 COUNTESS (*cont.*)
 Become the hero of this tale
 This path to true love will not fail

J C

I thought I **was** the hero of this tale?

COUNT

No

J C

Oh

COUNTESS

To become the hero of this tale
 Follow Belle on the mountain trail
 Until you reach the castle, where
 Her father is imprisoned there
 Captured by a beast was he -
 To be a hero . set him free!

J C

A beast?

COUNTESS

If Belle's Papa could be released
 From the clutches of this beast ò .

J C

B .. bõ beast?

COUNTESS

If you should do this one brave thing
 Then you will be the hero king

J C

I don't really do ò brave

COUNTESS

If you want Belle to be your wife
 You have to save her father's life
 My patience, now, is down to zero
 You're such a wimp . now be a hero

J C

How dare you speak to me like that ò .. don't you know who I am?

COUNTESS

You like to think that you're all that
 But you're nothing but a scaredy-cat

J C

Wimp? Scaredy-cat? I'll show you . I am Jean-Claude . handsome, talented, rich, popular .

This script is licensed for amateur theatre by NODA Ltd to whom all enquiries should be made.

www.noda.org.uk E-mail: info@noda.org.uk

and yes ò . brave. I will rescue Belle's father ò and you will eat your words ò ò just off to gather a bit of help ò ..

J C exits

COUNTESS

My plan is working very well
I want Jean-Claude to marry Belle
With Belle removed, the Prince's curse
Will never, ever be reversed
He'll stay a Beast . #il he can see
That he should choose to marry **me**
Ha ha ha ha ha

Scene 8 In The Mountains

A snow blizzard is blowing as Belle and Gigi struggle across the stage

BELLE

Oh, Gigi . are we nearly there? It's so cold ò . And I'm tired ò . I'll just have a short rest ò .

Belle sits down, cold and tired, she soon collapses into a deep sleep. Gigi tries to wake her, but can't – so tries to shelter her, until she falls asleep beside Belle

FAIRY

Don't give up now, my dearest Belle
You are the girl to break the spell
We knew that from the very start
That you could melt the Beast's cruel heart
We know that you're the one to go
We've seen the Disney video
So, wake, and continue on your quest
With a bit of magic (and a nice warm vest)
My fairy friends will help us out
Belle will succeed, there is no doubt

*Fairy casts spell. **Fairy snowflake ballet** ~ melts the snow ~ wakes Belle*

BELLE

Oh dear ò . What happened? I must have fallen asleep. But I feel warmer now . and stronger, too . and look! The snow has stopped. Come along, Gigi ò . show me the way ò .
(Gigi leads Belle to the castle doors. Belle rings the .. er ... bell. Gigi 'comedy-creeps' off)
Gigi! Don't go!
(Belle waits for a few seconds, then pushes the door – it opens ..)
Hello! ò .. is anyone home?

Scene 9 The Castle of Prince Louis

A suit of armour stands against the wall (person inside) A gauze portrait is hanging on the wall (person behind gauze). Lighting is subdued.

BELLE

Ooh, it's dark in here ò

The suit of armour clicks his fingers, and the lights come on

BELLE

ō .. and cold, too

The suit of armour clicks his fingers, and the fire lights up.

Belle is not aware of the movements of the suit of armour, but is a little bewildered by the events

PORTRAIT

(light-change, so that person is visible) Ooooh, that's better! Nice and warm! Nice of you to drop by!

Belle gasps, backs away, bumping into the suit of armour

ARMOUR

Ouch! Mind my foot!

Belle, shocked, runs to side apron of stage, to hide

PORTRAIT

You've frightened her now! ō . She looks hungry, she might come out again if we get her some food

ARMOUR

(nods) Maybe!

PORTRAIT

Dinner is served!

*Perhaps use a UV scene here, of a feast being prepared – food, plates, cups etc., choreographed in formation. Or it could be a dance.....whatever is in your imagination ☺
(See Additional Notes, for more staging details)
Music suggestions - "The Can-Can"*

BELLE

This is magical . I can't believe that it is the home of a wicked beast ō ..

BEAST *(off stage)*

WHO IS IN MY CASTLE?

(Beast enters)

WHAT ARE YOU DOING HERE?

BELLE

I ō . I ō I'm searching for my father

BEAST

THERE IS NO-ONE HERE BUT ME!

BELLE

But you **do** have my father here . I know you do ō

BEAST

THERE IS A STRANGER IN THE DUNGEON . HE DISTURBED MY SLEEP

BELLE

In the dungeon? But my father doesn't deserve that ō . Let me see him ō . I demand that you let me see him

This script is licensed for amateur theatre by NODA Ltd to whom all enquiries should be made.

www.noda.org.uk E-mail: info@noda.org.uk

BEAST
YOU DEMAND?! HOW DARE YOU SPEAK TO ME SO

BELLE
Please let me see my father . please let him go. If you set him free, then ð . I ð . I will take his place ð

BEAST
YOU? YOU WOULD DO THAT FOR YOUR FATHER?

BELLE
I would do anything for my father . I love him

BEAST
LET IT BE SO . I WILL SET HIM FREE. IF **YOU** WILL REMAIN HERE, IN HIS PLACE

Beast exits to fetch Papa

BELLE
Oh dear . what have I done? But I can't leave Papa here ð ..
(*Beast returns with Papa*) Papa! (*Belle & Papa hug*)

PAPA
Oh Belle! You shouldn't have come here

BELLE
But now you are free to go

PAPA
Is this true?

BEAST
YES . YOU MAY LEAVE . BUT YOUR DAUGHTER WILL STAY IN YOUR PLACE

PAPA
But Belle, I will not go and leave you here ð .

BELLE
But you must, Papa . your health is not good. I am young and strong, I will be fine here. I'm sure I will be able to return home soon

BEAST
GO NOW! OR I WILL CHOOSE TO KEEP YOU BOTH HERE!

BELLE
Go now, Papa, before it's too late

PAPA
I will go ð ð but I promise you, I will return

Belle & Papa bid a tearful farewell. Papa exits

BELLE
(*nervously*) Am I to live in the dungeon?

BEAST

This script is licensed for amateur theatre by NODA Ltd to whom all enquiries should be made.
www.noda.org.uk E-mail: info@noda.org.uk

YOU MAY WANDER THE CASTLE AS YOU WISH . BUT TRY TO ESCAPE AT YOUR PERIL!

Beast exits

BELLE

Looks AND charm! Must be my lucky day!

Short blackout, then lights up, to signify passage of time.

Scene 9a The Following Morning

Beast is sitting at the table. Belle stands, with her back to the Beast.

BEAST

BELLE! YOU WILL HAVE BREAKFAST WITH ME!

BELLE

(Turns to face Beast) I'm not hungry ò .

BEAST

I DEMAND THAT YOU EAT WITH ME!

BELLE

You may force me to stay in your castle . but you cannot demand that I eat with you

Belle exits, angrily. Beast looks and feels guilty. He starts to eat breakfast, but has lost his appetite and pushes it away. He walks to the rose & looks at it – two petals have already fallen.

BEAST

Belle ò if only she could love me ò . But not only do I have the body of a beast . but I behave like a beast ò . aggressive ò .. angry ò how could she possibly love me?

Belle returns

BELLE

I will have breakfast with you . if you treat me with a little kindness

BEAST

I WAS KIND ENOUGH TO FREE YOUR FATHER. NOW JOIN ME!

BELLE

Ahem!

BEAST

Would ò . you ò . join me for breakfast?

BELLE

I'd love to *(They sit and have breakfast)*

What do you do here all day? Do you read? I love books

BEAST

I don't read now ò ò .. I used to read ò .

BELLE

I love books . wonderful stories of Princes and dragons, magical forests and scary

This script is licensed for amateur theatre by NODA Ltd to whom all enquiries should be made.

www.noda.org.uk E-mail: info@noda.org.uk

creaturesō .

BEAST
GRRRR!
BELLE

Aaahh! *(she nearly falls off her chair)* Oh Iqñ sorry . I didnq mean to offend you

BEAST
If you like books . I have a library ò .. in the East Wing ò . it is yours

BELLE
A library?! How wonderful! Oh thank you! Will you show me the way?

Beast is a little surprised by Belle's friendliness, but is pleased. He exits, Belle follows.

Scene 10 A Street in the Village

A crowd has gathered to listen to Jean-Claude

J C
Hello people!
(Girls scream)
Thank you! Thank you! As Mr Popular Personality of Petit Pois, for the fifth year running . and, contrary to the scandalous tabloid stories, no money changed hands ò .

M. TRICOT
Just a few good bottles of wine and some nice jewelleryō

J C
ò . as I was saying, my talent, riches and an uncanny resemblance to Johnny Depp, have ensured that I remain the most popular guy in the village - but Iqñ here today to become your hero! Forget Superman, Batman and Harry Potter . Jean-Claude is here to save your village!

VILLAGER
From what, exactly?

J C
There is a terrible beast, living in a castle in the mountains . he has captured Monsieur Tres Jolie, the father of my darling Belle

M. TRICOT
Beast indeed! That manq a few fries short of a Happy Meal

J C
Iqñ telling the truth ò the wicked witch in the wood told me ò

M. TRICOT
Ooooh ò the wicked witch in the wood, eh? And what did the bogeyman under the bed have to say?

The villagers laugh at JC. He is very angry

J.C.
How dare you mock me, you old spinster! No wonder youqve been left on the shelf - why, if

This script is licensed for amateur theatre by NODA Ltd to whom all enquiries should be made.

www.noda.org.uk E-mail: info@noda.org.uk

you were my wife . I'd ō I'd ō poison your coffee ō .

M. TRICOT

Jean-Claude, if I **were** your wife ō . I'd drink it
Papa enters

VILL. 1

Look! There's Monsieur Tres Jolie . So Jean-Claude **is** lying!

VILL. 2

The things some people will say, to make themselves look good.

VILL. 3

Bonjour, Monsieur. Jean-Claude here, has been spinning some tale about a beast in the mountains ō

PAPA

It's true! And he has imprisoned my daughter, Belle . you must help me to save her

JC

I tell you the truth . if we do not kill the beast . it will kill all of us!

Jacques has entered

CROWD

KILL THE BEAST! KILL THE BEAST!

JACQUES

Wait! Listen to me! The Beast is not evil . he needs help!

Crowd exit, still chanting, leaving Jacques alone. The children remain at the rear of the stage – excitedly discussing what has been going on

JACQUES

Come back! Listen to me!

Oh, it's no use. I must hurry back to the castle, to warn Prince Louis

Jacques exits

Dame, Chard & Lamb enter

DAME

Hello everyone!

AUD

Hello Dolly!

Throws sweets

DAME

I don't know what's going on . the village is as empty as a Derby County (*replace with local team*) score sheet!

LAMB

It's as empty as Chard's head!

CHARD

How dare you! **Your** head's so empty . when you went to see that mind-reader ō he gave

This script is licensed for amateur theatre by NODA Ltd to whom all enquiries should be made.

www.noda.org.uk E-mail: info@noda.org.uk

you your money back!

LAMB

Ooooooh!!

They go for each other ... again

DAME

Charday! Lambrini! When are you going to grow up?!

(she looks around and sees the children)

Children! Come along and tell Madame Jolie what has been going on in the village ò

(The children move to the front. They are all shouting and speaking over each other)

CHILDREN

There's a beast! / It's going to kill us all! / It's got Belle! / They're going to kill it!

DAME

Did you say that a Beast has got Belle?

CHILD

YES! She's locked in his dungeon!

DAME

Oh no! My poor baby! Come along girls . best foot forward! We have to save your sister!

CHARD

From a B b b beast?

LAMB

Actually ò .I feel a bit ill today ò *(pulls a crumpled note from pocket)* here's a note from my mother

DAME

I AM your mother

LAMB

Oh yeah!

CHARD

I know! - someone has to stay and look after the café

LAMB

- good one, Charday . Yes, **we** volunteer to run the café whilst you are away

DAME

You are coming with me . to save your sister! Come along!

(Dame starts to walk off - the sisters turn and try to creep off in the opposite direction. Dame turns back) NOW!!!!

C & L

AAAAHHHH!!!!

Sisters jump. Then reluctantly follow Dame. Papa enters in a panic

PAPA

Oh, there you are Dolores . I've been looking everywhere for you ò . Something terrible's happened! I was captured by a beast . and now the Beast has captured -

DAME

- Belle. Yes, we know . we're just off to save her, aren't we girls?

C & L

(*not keen*) Yes, Mama

PAPA

I can take you to the Castle . and many villagers are already on their way

DAME

They will help us . come on, you can show us the way

PAPA

Follow me!

Scene 11 The Castle of Prince Louis

Belle is reading to Beast, they are sitting on the chaise longue, if used

BELLE

õ õ .. the animals watched as the handsome Prince leaned forward and kissed Snow White. Then, to their amazement, she opened her eyes and smiled. Their dearest Snow White was alive! Oh, how happy everyone was! õ õ .. Beast? õ .. Beast? Why õ . You're crying õ ..

BEAST

It just reminds me of something õ .. true love's kiss õ .. breaking a spell õ õ but that is just a fairy-tale

BELLE

I love this story . you have some wonderful books, and I love reading them with you

BEAST

Belle õ õ

BELLE

Yes

BEAST

õ nothing

Belle stands up and looks around

BELLE

This is a beautiful room õ . It's like a Royal Palace from one of my story books (*she starts to imagine...and talks as though she is re-enacting the story*) Cinderella curtsied to Prince Charming, and as the music started, they began to dance õ . (*she pretends to dance with Prince Charming, as music underscores quietly*)

BELLE

Can **you** dance?

BEAST

Dance?!

BELLE

Oh I love dancing ò .

BEAST

No ò ò ò I don't dance

BELLE

But it's such fun! Come on . have a go!

BEAST

I ò I'm not sure ò .

BELLE

I won't take no for an answer . come on! up you get!

Belle playfully pulls the Beast to his feet. The music builds as they begin to dance

BELLE

You dance well . I can't believe you're not danced before

Belle and the Beast continue to dance until they are downstage centre. They look at each other – and stop dancing ...

BEAST

Belle, do you think you could ever marry me?

Belle steps back, away from Beast – shocked

BELLE

MARRY YOU?? But you're a Beast ò .

BEAST

ò . and will always remain so ò .

BELLE

I'm sorry. We'll read again tomorrow.

Belle exits quickly. Beast shakes his head sadly, then walks over to the rose, which now has quite a few of the petals fallen off. Suddenly Jacques enters

JACQUES

Master! Master! Prince Louis!

BEAST

What is it, Jacques? I thought I told you never to return

JACQUES

I had to come back to warn you! It's the villagers . they're heading this way . and they want to kill you!

BEAST

Kill me?

JACQUES

Yes! They say that you have Belle imprisoned here ò

BEAST

Yes, Belle is here ò but I treat her well ò

JACQUES

I tried to stop them . but they wouldn't listen.

BEAST

Then I will await their arrival ò ò (*Beast goes to the rose*)...for if I am doomed to remain a Beast forever . then perhaps the villagers will end my misery ò ò .

Scene 12 A Corridor in the Castle

The Suit of Armour stands, motionless, on stage.

Dame and sisters enter – obviously lost

DAME

Well, this is the Beast's castle . but where did your father get to? And where are the other villagers?

CHARD

Oooh . I don't like it here ò .

LAMB

It's creepy ò .. I feel like we're being watched

DAME

Of course we're being watched . (*indicates to audience*) that's why they bought their tickets! Hello everyone!

AUDIENCE

Hello Dolly!

Throws sweets

The Suit of Armour is 'woken' by the noise – need to get audience reaction here

C & L

Shhhhhhh!!

CHARD

You'd wake the Beast!

LAMB

Ooooh . I was trying to forget about him

DAME

Now then . we have to find Belle. Which way shall we go? What about this way?

(Dame leads sisters over to stage left – Suit of Armour follows, behind them)

Hmmm . maybe we should go this way?

Dame leads sisters over to stage right – Suit of Armour follows. Lamb is last in line. As they all look over to the right, armour puts his right arm around Lamb's shoulders. Lamb looks right, counting 1 - Dame, 2 – Chard, 3 – self so who is 4????! Slowly looks left. Sees Armour - gasps in horror and runs off, stage left. Armour drops back again and stands still.

This script is licensed for amateur theatre by NODA Ltd to whom all enquiries should be made.

www.noda.org.uk E-mail: info@noda.org.uk

DAME (cont.)

I'm not sure ... what about that way (she moves to centre, pointing up the aisle)
 Chard realises Lamb is missing and is looking around, terrified. As Dame and Chard peer up the aisle, Armour taps Chard on shoulder – she looks around – gasps in horror and runs off stage

DAME (cont.)

What do you think, Chard may? (looks around, puzzled) Lambrini? Girls . this is no time to be playing hide and seek. we have to find your sister ... (to audience) where did they go? ... What did you say? ... (respond accordingly)

As Dame walks around the stage, searching – Suit of Armour follows her – each time the Dame looks at Armour, it is still – but she realises it seems to have changed places – Armour swings axe at Dame, but each time, she bends over or moves, just in time. Encourage audience response. Eventually, she twigs and moves right, then left, so that Armour follows. Then she pulls out a very large tin-opener... Armour runs off stage

Scene 13 The Castle of Prince Louis

Beast and Jacques are looking at the rose. The villagers' chanting can be heard as they get closer

VILLAGERS

KILL THE BEAST! KILL THE BEAST!

JACQUES

They're here, Your Highness! Shouldn't we hide or something?

Jean-Claude leads the crowd as they enter. Jacques heroically jumps in front of the Beast to protect him

JACQUES

You must not harm him! He will not hurt you!

J-C

Oh, it's you again! Out of my way, small-fry!

J-C pushes Jacques to the ground

JACQUES

I'm getting fed up of this!

BEAST

GRRRRRRRRRRRR!!!!

J-C

AAAHHHHH!!!!

J-C hides behind the nearest lady. Jacques jumps up

JACQUES

Not so brave now then, eh Jean-Claude? Where's he gone?

The crowd look around for J-C, but he has crept around the back and up onto the raised stage behind the Beast (a sturdy chair will suffice!).

JACQUES

Look out!!!

Before the Beast has chance to realise, J-C lifts his sword and stabs Beast in the back. The Beast growls with pain, then collapses. Jacques runs to Beast.

JACQUES

Oh Master, Master ò

BEAST

Please, Jacques ò .. find Belle ò ò .

Jacques exits shouting for Belle

Scene 14 A Corridor in the Castle

Jacques runs on stage – searching for Belle

JACQUES

BELLE! BELLE! Where are you? BELLE!

Belle enters – surprised to find someone else in the castle

BELLE

Who are you? ò ò . But I didn't think that there was anyone else here in the castle ò .. Haven't we met before?

JACQUES

Yes Jacques . but you must come quickly . Prince ò . er ò the Beast is injured ò . I think he's dying ò

BELLE

- what's happened?!

They both run off – Belle following Jacques

Scene 15 The Castle of Prince Louis

The Beast's mask/head lies on a pillow on a makeshift bed (a chaise longue if used) Prince Louis is hidden under the bedclothes. Jacques and Belle run into the room. Jean-Claude stands proudly, bloodied knife in hand. The rest of the crowd is rather unsure of how to react and they look worried and uncomfortable

J-C

Ah, Belle! I am your hero! *(he drops to one knee)* You will now become my wife!

Belle pushes him over

BELLE

Oh shut up, Jean-Claude!

J-C collapses in a heap. Belle runs over to Beast

J-C

But Belle . I'm handsome, talented, rich, heroic ò

CROWD

OH SHUT UP JEAN-CLAUDE!

As Belle stands by Beast – the crowd opens out to the sides of the stage

BELLE

Beast! What has happened? You can't die ò . I ò ò I love you!

As she leans over to kiss him, the stage lights slowly dim. Magical effects, using a mirror-ball or gobo lighting effect. As Belle leans forward to cover Beast – the Prince emerges, having hidden the mask. After the kiss – Belle jumps back in surprise

BELLE

ò . who are you? Where is the Beast?
Prince stands

PRINCE

I am Prince Louis ò . I **am** the Beast

BELLE

You?

JACQUES

Prince Louis! Oh, Belle . the spell has been broken!

BELLE

Spell? What spell?

Countess enters

COUNTESS

I turned the Prince into a Beast
I did not want the Prince released
Until he agreed to marry **me**!
But meddling **Belle** has set him free
I'll teach you to get in my way
The time has come to make you pay!

*She raises her arms - sound of thunder & lights flash.
Fairy enters and raises her wand*

FAIRY

Just stop right there, my evil friend
You're not to spoil this happy end
And so . Ann Robinson's little sister
Go find yourself some other mister

Fairy waves wand. Countess, trance-like, makes her way towards J-C

COUNTESS

Mean and selfish . just like me
A well-matched pair we'll prove to be

This script is licensed for amateur theatre by NODA Ltd to whom all enquiries should be made.
www.noda.org.uk E-mail: info@noda.org.uk

J C

But ò what about Belle? ò . she loves me

ALL

Oh no she doesn't!

J C

Oh

*Countess clicks fingers, and J-C follows Countess. They exit.
Then, Dame & Sisters enter, followed by Papa*

DAME

We've come to save Belle!

BELLE

Better late, than never, I suppose! I'm here Mama! Hello, Papa!

PAPA

Belle, I was so worried, leaving you here with that terrible Beast

DAME

Where is it then . this terrible Beast? Did Jean-Claude kill it?

BELLE

Very nearly. It's a long story . but the Beast has gone.

CHARD

Pleased to hear it . who's the guy with the nice legs?

BELLE

This is Prince Louis ò ..

LAMB

Prince Louis ò ò . well ò hello!

CHARD

(pushing Lambrini out of the way and offering out her hand) I'm Chard'ay! ò .. but don't you think that Princess Chard'ay has quite a ring to it?

PRINCE

I think that Princess Belle has quite a ring to it

JACQUES

Oh, very funny, Your Highness

PRINCE

But seriously, Monsieur, I would like to ask for your daughter's hand in marriage

C & L

WHO ME??!!!

PRINCE

No, **Belle**

PAPA
Yes, I .

DAME
(pushes to front, interrupting Papa) Of course you can marry Belle . just call me Mum!

PRINCE
(Prince kneels) Belle . will you marry me?

BELLE
Yes, Prince Louis, I will

CHARD
Have you got any brothers?

LAMB
Cousins?

DAME
Distant relations with lots of money .

PAPA
- preferably short-sighted?

PRINCE
I have many relations . you will meet them all at the wedding! But first . a celebration party!
Everyone is invited!

DAME
Oooh! I love a good party!

CHARD
Better go and get ready!

LAMB
- make ourselves even more gorgeous!

Everyone exits, talking about the party – leaves Louis & Belle on stage

SONG *From this Moment+*~ Belle and Prince

Song Sheet

Papa & Jacques enter

JACQUES
Well ò your daughter, Belle ò and my best friend, Prince Louis ò they make a lovely couple, don't they?

PAPA
Yes they do

JACQUES
Well, how come you're looking so sad?

PAPA

This script is licensed for amateur theatre by NODA Ltd to whom all enquiries should be made.
www.noda.org.uk E-mail: info@noda.org.uk

Oh õ nothing reallyõ õ Well actually, I've lost MY best friend . my horse, Gigi õ . I haven't seen her since I was locked in the castle dungeon

JACQUES

Oh dear õ õ

Gigi's head appears from wings – hopefully audience will notice!! A bit of 'toing and froing' with audience – notice Gigi - big hugs

JACQUES

Oh, that's nice . I do like a happy ending! Shall we go and get ready for the party now then?

Gigi shakes her head

PAPA

No? why not?

(Gigi hooves the ground – Papa watches and nods knowingly)

Gigi says that we have a very important job to do first õ .

(Jacques looks bemused at Papa & Gigi)

We have to sing a song with all of the boys and girls out there

JACQUES

THE HORSE said that?

Gigi exits

PAPA

Yes . she's very clever õ . She's just gone to fetch the words to the song õ

JACQUES

- what? She writes as well?!

PAPA

No! Don't be ridiculous . horses can't write!

JACQUES

(still a bit bemused) I wasn't aware that they could speak until now! Anyway . I have a few people to say hello to õ ..

HELLO / HAPPY BIRTHDAY LIST

Gigi back on stage – along with assistants carrying song board

PAPA

Oh Gigi . I see you've chosen one of YOUR favourite songs õ I hope that the children will know it õ .. some of the **much older children** might! But I think we may need a bit of help up here õ . Does anyone want to come up and give us a hand?

Papa and Jacques interview the children “ ... and how old are you?” “Six? Fancy that! I was six when I was your age!” – you know the sort of thing!

SONG %Four-Legged Friend+

*They sing the song – Altogether, then one side at a time, in competition.
Perhaps Gigi can decide the winners?*

JACQUES

Well that was fun . but it's time we went and got ourselves ready for the party

PAPA

Can I bring Gigi?

JACQUES

Of course you can bring Gigi . come on!

All exit

Finale

Walkdown & Bows

SONG %Everything's Coming Up Roses+

FAIRY

I promised you a happy tale . although at times, I thought we'd fail

DAME

So here we are . our panto's done . I hope you're all had lots of fun

CHARD

And if you're single, young and free

LAMB

We're in dressing room number three!

JACQUES

Just one more thing to wish you here

ALL

A very Merry Christmas and a Happy New Year!

Additional Notes

Music Content

Your choice of music is important; choose songs that are suited to your company and your audience. In general, it is best that songs are well-known and kept fairly short. Up-tempo songs work well, but you will usually need to include at least one slower ballad, or love song. It is likely that most of your audience will be familiar with chart music, rather than musicals. Whatever you choose, remember that the performance of any copyright music (including those suggestions made in this script) is subject to permission and payment of royalties. The Performing Rights Society licenses most popular songs and also collects royalties.

Staging

1. The Beauty Parlour

This scene looks very effective if the props, set and costumes are all predominantly bright pink!

The Arm Stretching+

Long striped socks or tights with false hands attached. Dame puts the sock over her hand and gathers it up her arm (she'll need sleeves in her costume, to cover this). She holds the false hands with her own hands, until it is time for the stretching+

The Dressing Table and Sinks

This can be incorporated into one piece of equipment. Basically, it is a small table with a deep edging added. A hollow frame is set in the centre. Two shower heads/hoses are attached to the upstage side of the table. The sinks+ can be painted on, or make a large hole each side of the top surface, and insert a small bowl or basin.

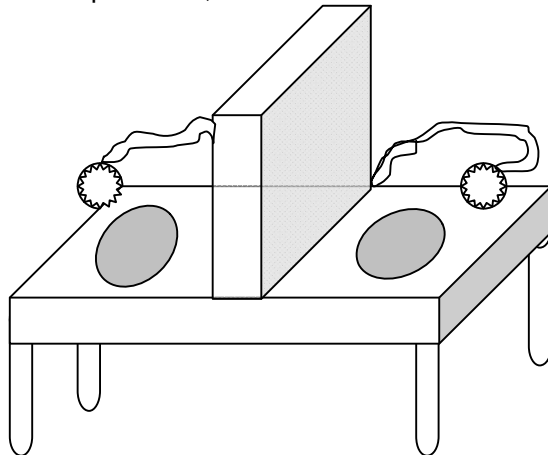

The Steam Chamber

This is a simple box shape, but it needs to be big enough to fit over the Dame. In its simplest form, it can be bottomless, with the Dame walking it on stage+. A blast of smoke+ into the box, just before it comes on stage, will add to the steam+ effect.

The dotted line represents the false panel inside, in front of which, is hung the shrunk Dame+ (just a rag doll, dressed the same as the Dame). The false panel is merely a curtain of black fabric, Velcro-ed to the inside top of the steam chamber+. The Dame can easily remove this herself, and hide it behind her.

This script is licensed for amateur theatre by NODA Ltd to whom all enquiries should be made.

www.noda.org.uk E-mail: info@noda.org.uk

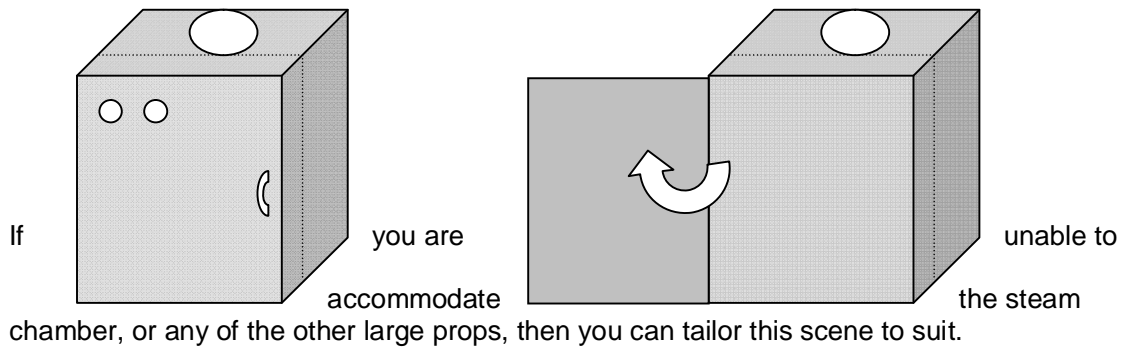

Massage Table

This is built with sides deep enough for Lambrini to kneel inside it. False legs (stuffed tights, exactly the same as Lambrini is wearing) are attached top one end of the table. A large towel is used to cover Lambrini and the top of the false legs.

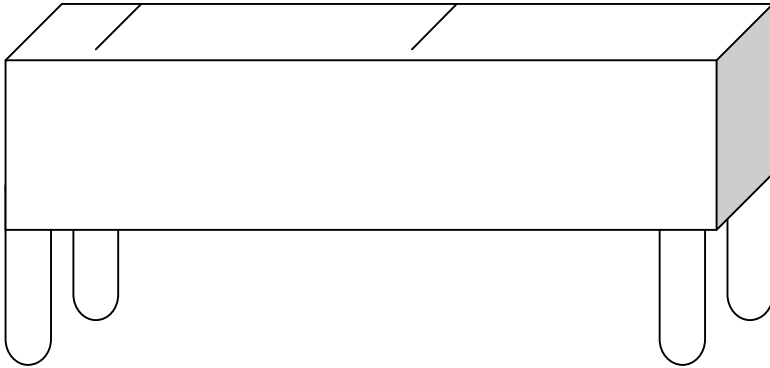

N.B. The script indicates the use of screens for this scene (eg to hide Lambrini when she is getting into the massage table). However, you may find it easier to bring in the tabs quarter-way, instead, then take them out again, as required.

2. Change of Prince to Beast

This can be as simple as using dimmed lighting and some smoke, having the Prince quite close to the wings ~ then a quick changeover. Dramatic music will always enhance this type of moment.

Or, if you can accommodate it (and build it), this transformation can be a ~~wow~~ wow+moment, if you use a revolve, built into the set. Two identical thrones are built, back-to-back, one each side of a panel, or curtain. They are set on a revolving section of floor, which is set into a platform base.

Dim lighting & lots of smoke helps, too!! At the start of the spell, the Prince staggers back & sits on the throne, he holds his head as though in pain. Build-up the atmosphere with lights/drum roll/music & lots of smoke & a pyro could be employed to provide further ~~wow~~ wow+, if you wish. The revolve is spun, at exactly the right moment, by members of the backstage crew. The Beast is already sitting on the other throne, head in hands. This involves a lot of work, and the timing must be exact, but it is very effective.

3. In the Mountains

This script is licensed for amateur theatre by NODA Ltd to whom all enquiries should be made.
www.noda.org.uk E-mail: info@noda.org.uk

This scene is quite short, and is used twice, so don't make it too complicated to set up. A Snowy Mountain backcloth is best, preferably on a mid-stage track, if you can accommodate this. If not, white snow falling in front of a plain background will still create the desired effect. Or paper snow could be used, it is cheap, and fairly easy to drop from above.

Or use dancers, trailing white fabric. This can look effective, if done well, and there are lots of chiffon-type fabrics on sale, some even have snowflakes already printed on. The fabric can be laid over Belle and Gigi, to represent their being covered with snow.

The newer snow machines that blow out snow made from foam are very effective, and can be fairly inexpensive to hire. However, they are quite noisy, so you may have to add some underscore music!

A snow scene is always a good opportunity for a snowflake ballet if you have dancers.

4. UV scene

This type of musical number can be very effective using ultra violet lighting:-

Various items of cutlery, crockery, food etc can be used. Or just use giant cutlery, and simple but well-timed choreography. Let your imagination take over!

Whatever props you decide to use, paint them with an undercoat, followed by two coats of UV reactive paint.

The operators must be dressed completely in black, including hoods, socks and gloves. Usually, it is best to use dancers for this job, as they are more nimble, with good spatial awareness.

Ensure that the operators are always behind the UV-painted object. Attach handles to the back of each prop. for ease of operation.

NB When using UV reactive paint, make sure that there are no gaps in the paintwork (or any paint where it shouldn't be!). Use a sufficient number of UV lighting tubes. Ensure that all other light sources are switched off (including the musicians lights). And a UV scene must have a black background!